

Scanning **Film** using Epson Scan V850 Pro Scanner

Medium Format, 4"x5", and 35mm Film

Table of Contents

<i>I. Equipment</i>	2
<i>II. Getting Started</i>	2
<i>III. Start Scanning</i>	3
<i>IV. Scan in Full Auto Mode:</i>	5
<i>V. Scan in Home Mode:</i>	6
<i>VI. Scan in Professional Mode</i>	8
<i>VII. Previewing and Scanning in Home and Professional Mode</i>	9

I. Equipment

This digitization project requires:

- **Epson Perfection V850 Pro Scanner** (already set up at Digitization on Demand station)
- Film holder - medium format or 4"x5" (available to check out at CCC desk)

Scanner Parts

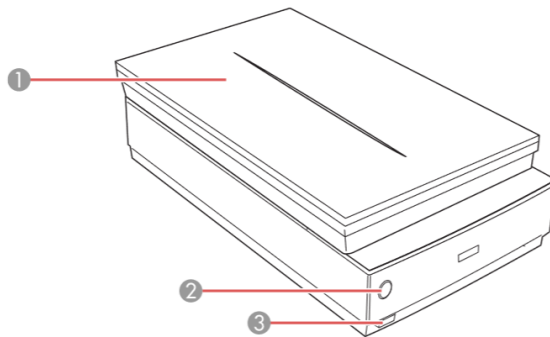

- 1 Scanner cover
- 2 The ⏻ start button
- 3 The ⏻ power button

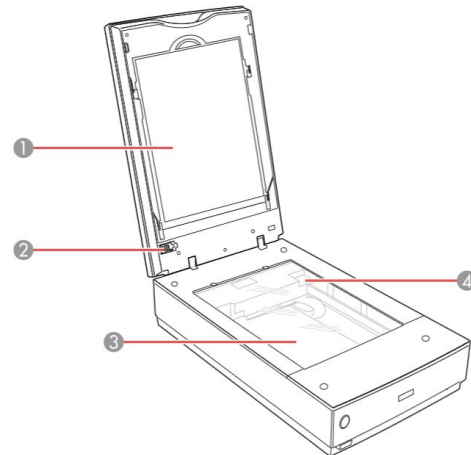

- 1 Document mat
- 2 Transparency unit transportation lock
- 3 Scanner glass
- 4 Carriage (beneath scanner glass)

II. Getting Started

Log in to the Digitization on Demand computer. You can log in with your library card or a guest pass.



Press and hold the **power button** to turn on the scanner.

It is in the bottom left corner. A green light will come on.

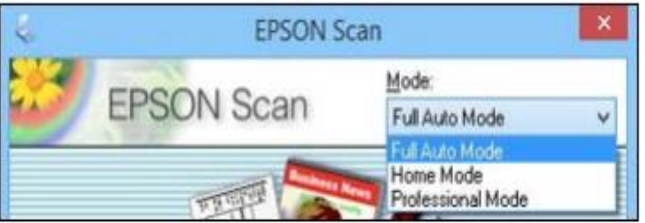
	<p>Double click on the Epson Software icon on the computer desktop.</p> <p>Select Epson V800/V850 from the list that pops up.</p>
	<p>Choose a Mode from the list in the top right corner of the Epson Scan window.</p> <p>You cannot use Full Auto Mode for Medium Format Film.</p>

Full Auto Mode (p.5): The easiest way to scan. The program will automatically choose the best settings for your scan.

Home Mode (p.6): This mode offers more choice. You can select some settings such as scan, preview, and size options.

Professional Mode (p.8): This mode offers full control. You can choose all settings, previews, and size options for your scanned image.

III. Start Scanning

Open the scanner cover and **remove the white document mat** (on the inside cover) by pulling up on the handle.

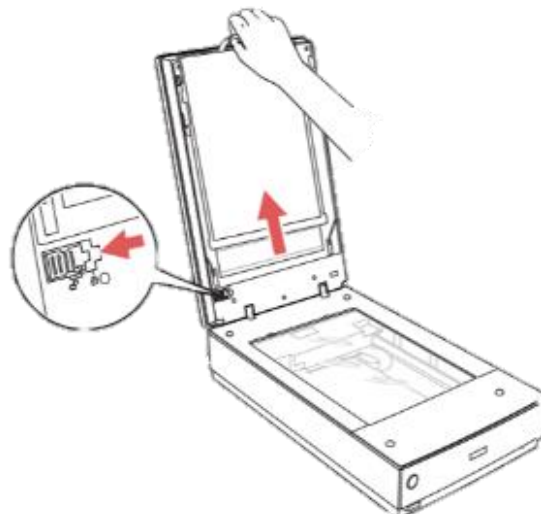

Put your film into the holder shiny side up (not backwards).

Gently close the film holder cover and press it down until it clicks into place. Make sure film is not pinched or curled.

*Image on the right is of **medium format film**. 35mm and 4" x 5" film will look different, but the same instructions apply.*

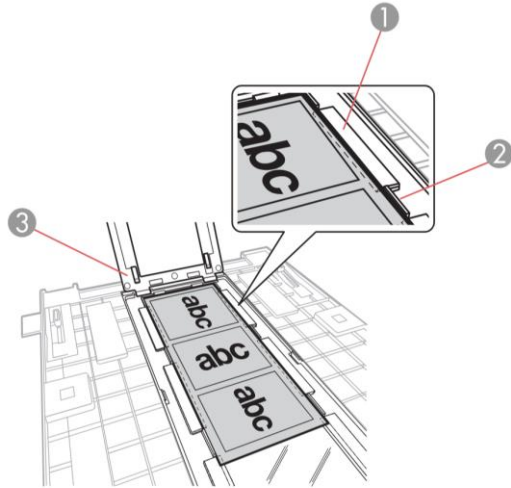

- 1 Film lock bevel
- 2 Film guide tab
- 3 Film holder cover

Turn the film holder over.

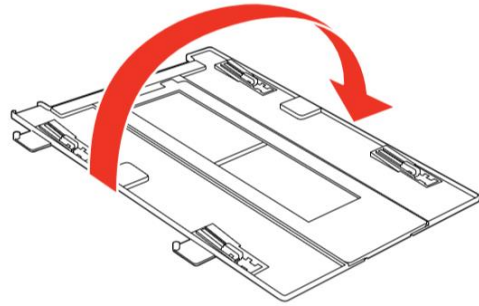



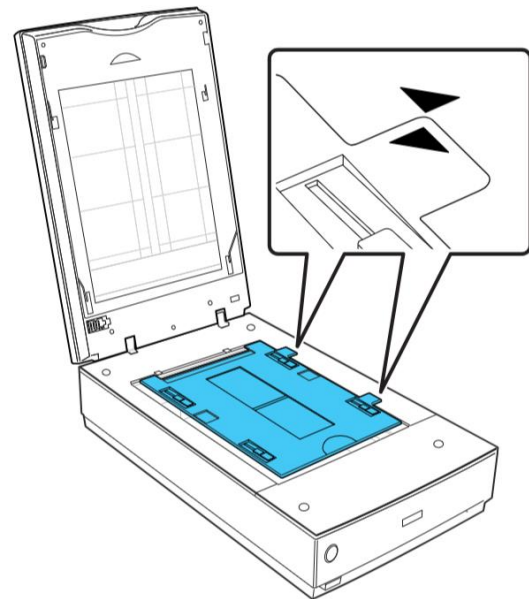

Place the holder on the scanner glass. Line up the arrows on the holder so they are pointing at the arrows on the scanner (as shown).

Pegs should sit easily in the holes. There is no need to push down.

Close the Scanner Cover.

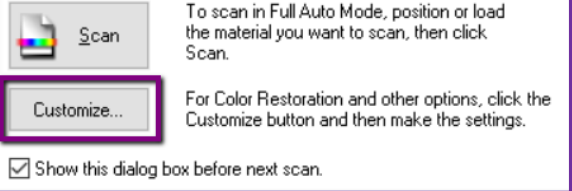

IV. Scan in Full Auto Mode:

<p>This section only applies to 35mm and 4"x5" film. You cannot scan medium format film in Full Auto Mode.</p>	
 <p>To scan in Full Auto Mode, position or load the material you want to scan, then click Scan.</p> <p>For Color Restoration and other options, click the Customize button and then make the settings.</p> <p><input checked="" type="checkbox"/> Show this dialog box before next scan.</p>	<p>Optional: You can click Customize if you would like to decide:</p> <ul style="list-style-type: none"> • where a scan saves to on the computer (destination folder) • the file format (.jpeg, .pdf, etc.) • the scan quality (resolution).
 <p>To scan in Full Auto Mode, position or load the material you want to scan, then click Scan.</p> <p>For Color Restoration and other options, click the Customize button and then make the settings.</p> <p><input checked="" type="checkbox"/> Show this dialog box before next scan.</p>	<p>Click Scan.</p>
<p>The scanner will automatically detect the number of photos on the film in the scanner and save each as an individual image.</p> <p>When the scan is finished, the Epson scan window will automatically close and open the folder where your photos are saved on your computer.</p> <p>If you wish to scan more photos, you will need to relaunch the program.</p>	
<p>NOTE: If your final scanned images appear upside down, you can change this by opening your scanned photos in the Microsoft Photos Application  and using the "Edit"  feature. This will not work if you chose to save your scans as PDFs.</p>	

V. Scan in Home Mode:

Home Mode: This mode offers more choice. You can select some settings such as scan, preview, and size options.

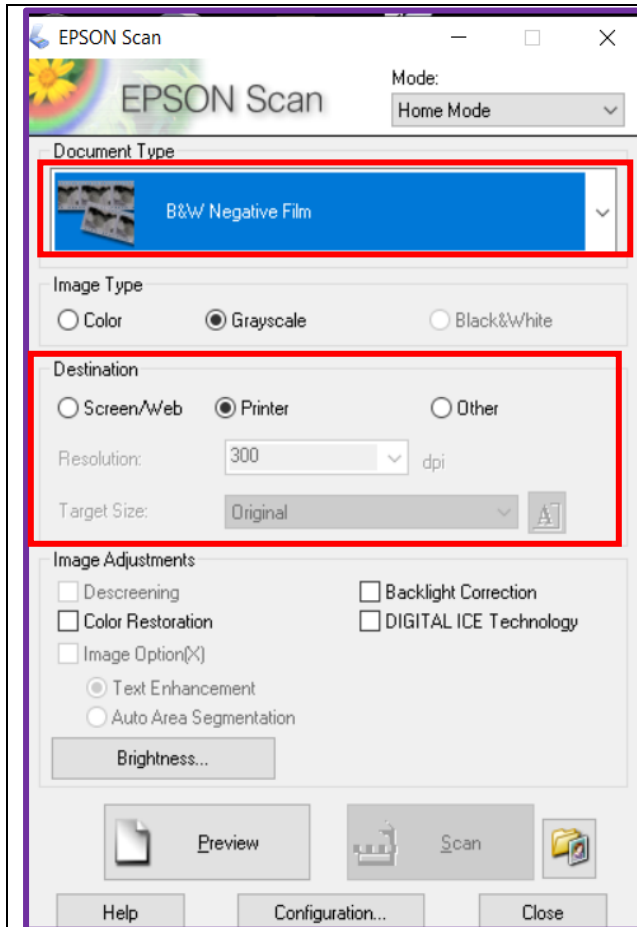

Under **Document Type**, select your film type.

Options: **B&W Negative Film**, **Positive Film**, or **Colour Negative Film**.

Under **Destination**, select the best preset for your project.

Printer is higher quality (larger) than **Screen/Web** (smaller).

If you're not sure, you can select **Other** and set the quality of your scan manually.

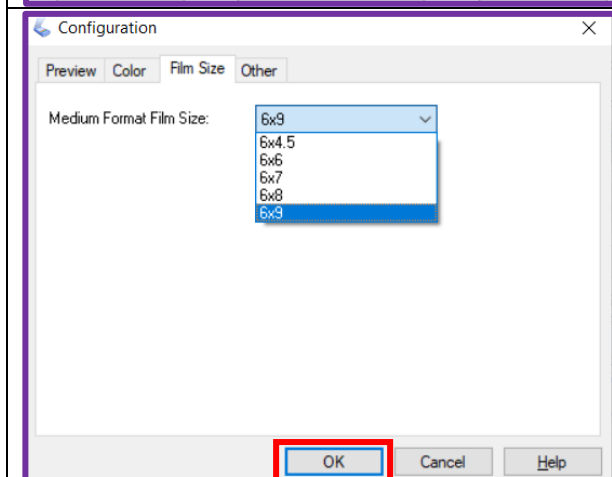

For Medium Format Film only:

Before previewing, click **Configuration...** to select your film size.

Click **Film Size** from the top tabs. Select your film size from the drop-down menu.

Click **OK**.

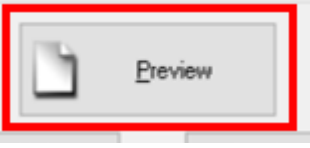
	<p>Before you can scan, you must Preview your film.</p> <p>A new window will open, showing you a scan preview.</p>
---	---

Jump to section **VII. Previewing and Scanning in Home and Professional Mode** for next steps.

VI. Scan in Professional Mode

Professional Mode: This mode offers full control. You can choose all settings, previews, and size options for your scanned image.

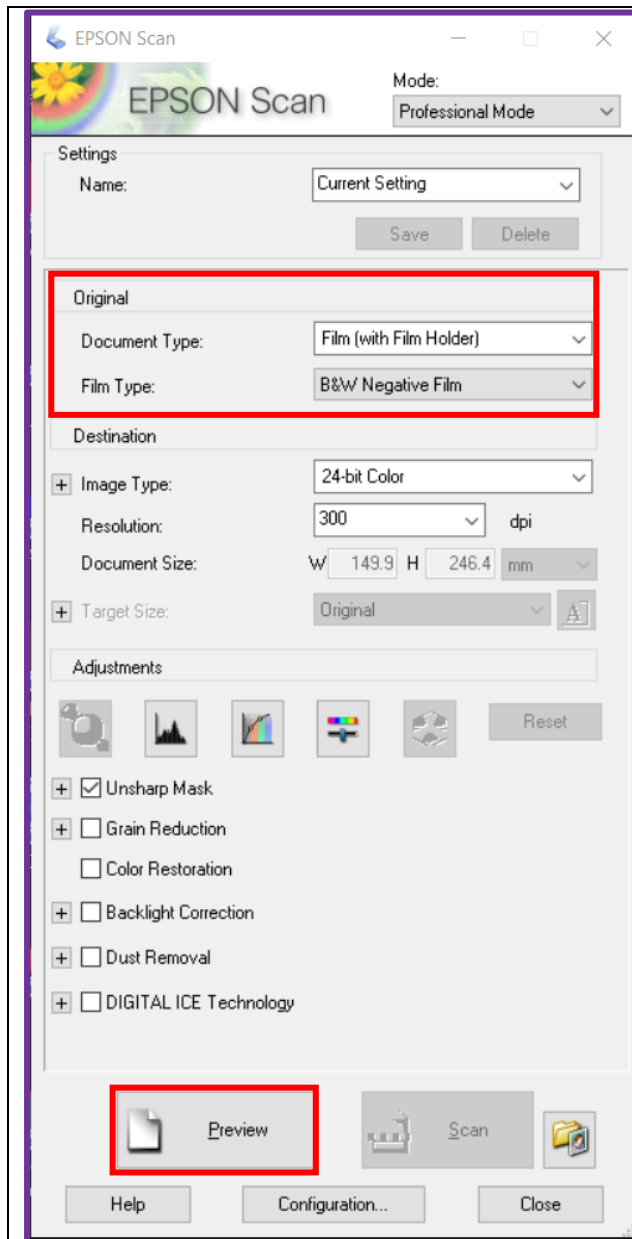

Under **Original**, choose options that describe the film you are scanning.

- **Document Type:** Choose **Film (with Film Holder)**
- **Film Type:** Choose from **B&W Negative Film, Positive Film, or Colour Negative Film.**

Under **Destination**, choose your **Image Type** and **dpi** (dots per inch).*

*See **Glossary** for description of options.

Before you can scan, you must **Preview** your photos.

A new window will open, showing you a scan preview.

VII. Previewing and Scanning in Home and Professional Mode

Note: Home Mode and Professional Mode look slightly different. Professional Mode has more options and a slightly different layout. The below instructions generally apply to both modes.

Epson Scan software automatically finds the images you put in the scanner. The preview window will show you each individual image.



To select and edit your scan previews, ensure you are on the **Thumbnail** tab of the preview window.

You can choose the size of your scan previews under **Size** on the left.



A solid blue line around a preview means that you are *editing* it. The checkmark means it will *scan*.

To select multiple scan previews to edit, hold down the CTRL key on your keyboard while clicking on the images you would like to select.

To select all scan previews to edit, select **All** under **Frame** on the left.

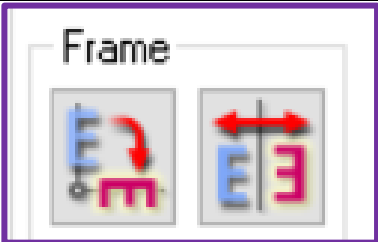
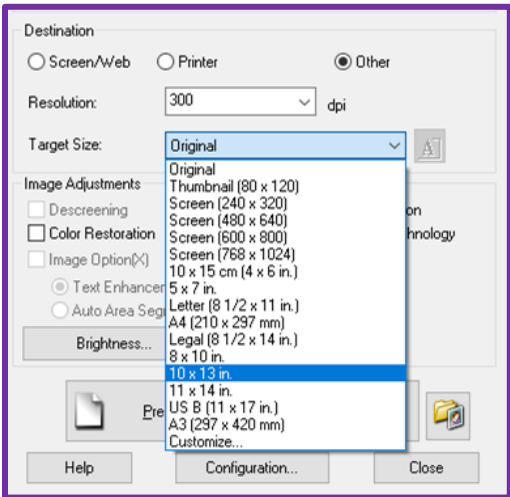
	<p>To Crop your scan previews:</p> <p>Hold your mouse in the top left corner of your selected scan. A + sign will appear, and a dotted line will surround your scan.</p> <p>Use the double-pointed arrow to click, hold, and drag the dotted box to the desired size.</p> <p>Only the area included within the dotted line will appear in your finalized scan.</p>
	<p>Under Frame, you can Rotate (90° clockwise) and Flip (mirror) your scan previews.</p>
	<p>In the original Epson Scan window, you can decide the target size and resolution for your final scans.</p> <p>Any scan preview that is selected in the Preview Window will show the changes you make.</p> <p><i>Image to the left is of Home Mode.</i></p>

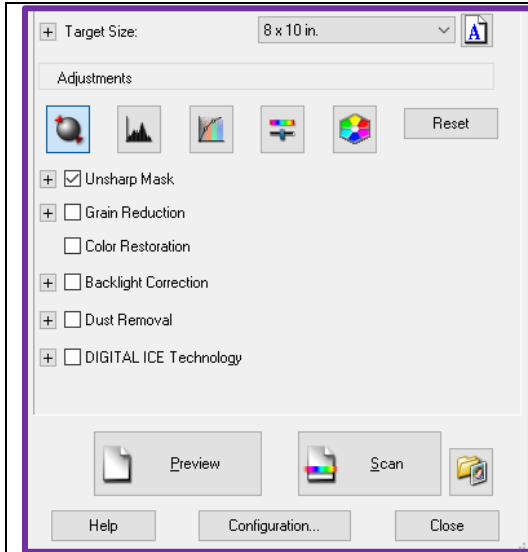

During the selection process, you can also choose to make adjustments to the colour or quality of your scan.

Image to the left is of Professional Mode.

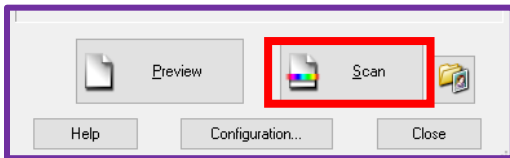
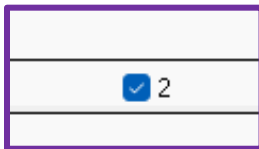

Ensure that all of the preview scans you wish to finalize and save as full scans are **checked** (blue check box).

When you are ready to finalize your scans, click **Scan**.

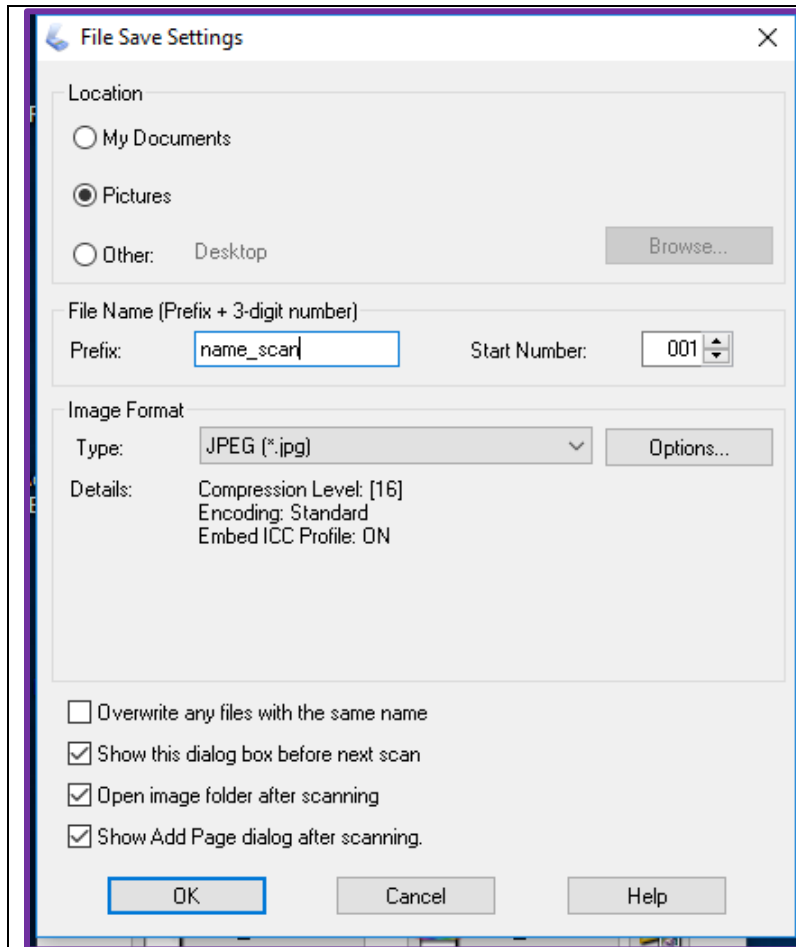

The **File Save Settings** window will pop up.

Under Location, choose where you would like to save your scans. To find a specific folder, click **Browse...**

Under **File Name**, choose a prefix. If you are scanning multiple photos, each scan will save as that prefix with a number following it (i.e. Prefix001, Prefix002, Prefix003, etc.).

Choose your **Digital Image Format** (i.e. JPEG, PNG, TIFF, etc.).

Click **OK**.

When the scan is finished, close the Preview Window.

You will find your final scans in **File Explorer**  in the folder you chose in the step above.

Copy the file(s) to your USB storage device or save to a cloud storage service.

Repeat or Finish: If you would like to scan another batch, repeat the process. If you are finished, close the Epson Scan application.